

Installation Instructions

EH-RIO DeviceNet Communication Interface (RIO-DNP)

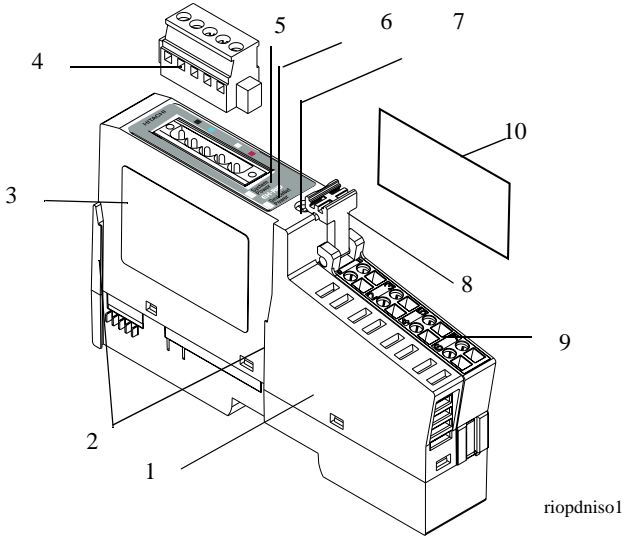

	Description		Description
1	RIO-DNP DeviceNet Communication Interface Module	6	DeviceNet Power Indicator
2	Interlocking side pieces	7	DIN Rail Locking Screw (orange)
3	Module label	8	RTB Removal Handle
4	DeviceNet connector	9	Removable Terminal Block (RTB)
5	System Power Indicator	10	Safety End Cap

ATTENTION



EH-RIO is grounded through the DIN rail to chassis ground. Use zinc plated, yellow chromated steel DIN rail to assure proper grounding. Using other DIN rail materials (e.g. aluminum, plastic, etc.) which can corrode, oxidize or are poor conductors can result in improper or intermittent platform grounding.

Installing the Communication Interface

To install the communication interface on the DIN rail, proceed as follows.

1. Position the communication interface vertically above the DIN rail.
 2. Press down firmly to install the communication interface on the DIN rail.
 3. The locking mechanism will lock the communication interface to the DIN rail.
 4. Remove the safety end cap (10) by sliding it up to expose the backplane and power interconnections.
-

ATTENTION



Do not discard the end cap. Use this end cap to cover the exposed interconnections on the last mounting base on the DIN rail. Failure to do so could result in equipment damage or injury from electric shock.

If installing a replacement communication interface to an existing system:

1. To remove the communication interface from the DIN rail, pull up on the RTB removal handle (8) to remove the terminal block.

2. Use a small bladed screwdriver to rotate the DIN rail locking screw (7) to a vertical position. This releases the locking mechanism.
3. Lift straight up to remove.
4. Position the communication interface (1) vertically above the DIN rail.
5. Slide the communication interface down allowing the interlocking side pieces to engage the adjacent module.
6. Press firmly to seat the communication interface (1) on the DIN rail. The communication interface locking mechanism will snap into place.

European Communities (EC) Directive Compliance

If this product has the CE mark it is approved for installation within the European Union and EEA regions. It has been designed and tested to meet the following directives.

EMC Directive

This product is tested to meet the Council Directive 89/336/EC Electromagnetic Compatibility (EMC) by applying the following standards, in whole or in part, documented in a technical construction file:

- EN 50081-2 EMC — Generic Emission Standard, Part 2 — Industrial Environment
- EN 50082-2 EMC — Generic Immunity Standard, Part 2 — Industrial Environment

This product is intended for use in an industrial environment.

Low Voltage Directive

This product is tested to meet Council Directive 73/23/EEC Low Voltage, by applying the safety requirements of EN 61131-2 Programmable Controllers, Part 2 - Equipment Requirements and Tests. For specific information required by EN 61131-2, see the appropriate sections in this publication, as well as chapter 9 on PLC installation in the user's manual for the Hitachi EH-150 Series PLC, publication NJI-281(X)E.

4 EH-RIO DeviceNet Communication Interface

Open style devices must be provided with environmental and safety protection by proper mounting in enclosures designed for specific application conditions. See NEMA Standards publication 250 and IEC publication 529, as applicable, for explanations of the degrees of protection provided by different types of enclosures.

Wiring the Communication Interface

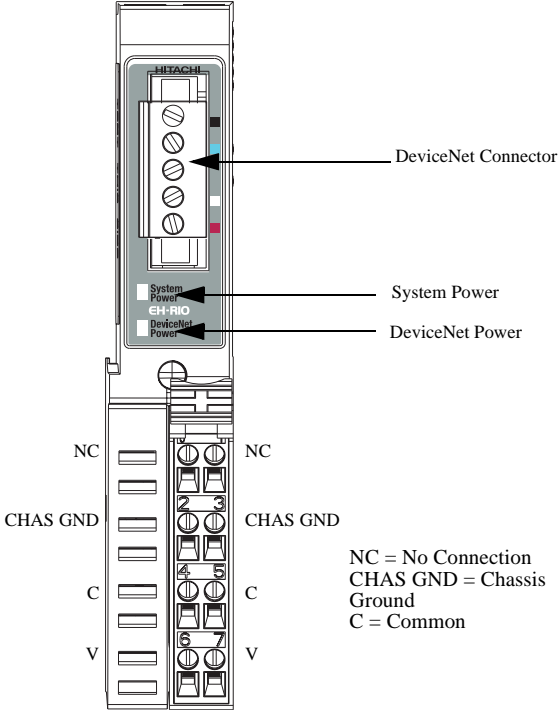

12/24V dc Wiring

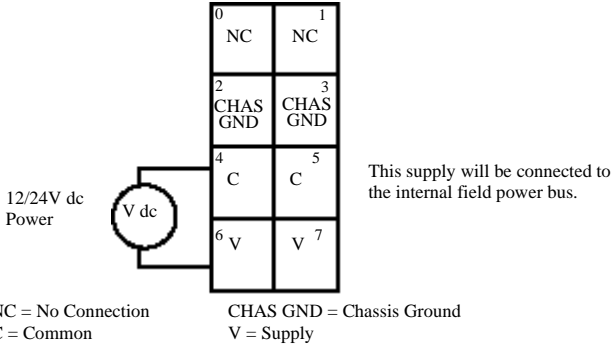

Connect	Terminal
+V dc	6
-V dc	4
Chas Gnd	2

12/24V dc becomes the internal power bus for modules to the right.

120/240V ac Wiring

120/240V ac

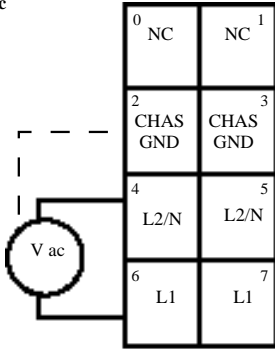

This supply will be connected to the internal power bus.

L2/N = Neutral, L1 = 120/240V ac
 CHAS GND = Chassis ground

Connect	Terminal
L1	6
L2/N	4
Chas Gnd	2

120/240V ac becomes the internal power bus for modules to the right.

DeviceNet Wiring

DeviceNet connection

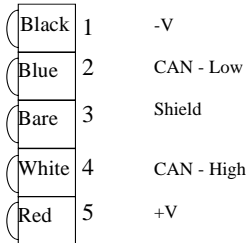



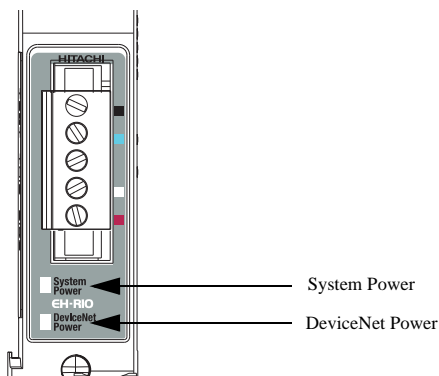



Troubleshooting with the Indicators



Indicator	Indication	Probable Cause
System Power	Off	Not active. DeviceNet power is off, or dc-dc converter problem.
	Green	System power on. dc-dc converter active (5V)
DeviceNet Power	Off	Not active. DeviceNet power is off.
	Green	Power on, 24V present

Safety Approval

C-UL and UL Hazardous Location Approval	Approbation d'utilisation dans des environnements dangereux par la C-UL/UL
<p>C-UL and UL certifies products for general use as well as for use in hazardous locations. Actual C-UL and UL certification is indicated by the product label as shown below, and not by statements in any user documentation.</p>	<p>La C-UL/UL certifie des produits pour une utilisation générale aussi bien que pour une utilisation en environnements dangereux. La certification C-UL/UL en vigueur est indiquée par l'étiquette produit et non par des indications dans la documentation utilisateur.</p>
<p>Example of the C-UL and UL certification product label:</p> 	<p>Exemple d'étiquette de certification d'un produit par la C-UL/UL :</p> 
<p>To comply with C-UL and UL certification for use in hazardous locations, the following information becomes a part of the product literature for this C-UL and UL-certified industrial control product.</p> <ul style="list-style-type: none"> This equipment is suitable for use in Class I, Division 2, Groups A, B, C, D, or non-hazardous locations only. The products having the appropriate C-UL and UL markings (that is, Class I, Division 2, Groups A, B, C, D) are certified for use in other equipment where the suitability of combination (that is, application or use) is determined by the C-UL and UL or the local inspection office having jurisdiction 	<p>Pour satisfaire à la certification C-UL/UL en environnements dangereux, les informations suivantes font partie intégrante de la documentation des produits de commande industrielle certifiés.</p> <ul style="list-style-type: none"> Cet équipement ne convient qu'à une utilisation en environnements de Classe I, Division 2, Groupes A, B, C, D ou non dangereux. Les produits portant le marquage C-UL/UL approprié (c'est-à-dire Classe I, Division 2, Groupes A, B, C, D) sont certifiés pour une utilisation avec d'autres équipements, les combinaisons d'applications et d'utilisations étant déterminées par la C-UL/UL ou le bureau local d'inspection qualifié.
<p>Important: Due to the modular nature of a programmable control system, the product with the highest temperature rating determines the overall temperature code rating of a programmable control system in a Class I, Division 2, location. The temperature code rating is marked on the product label as shown.</p>	<p>Important: De par la nature modulaire des systèmes de commande programmables, le produit ayant le code de température le plus élevé détermine le code de température global du système dans un environnement de Classe I, Division 2. Le code de température est indiqué sur l'étiquette produit.</p>
<p>: Temperature code rating:  CL I, DIV 2 GP A,B,C,D TEMP </p> <p>Look for temperature code rating here.</p>	<p>Code de température :  CL I, DIV 2 GP A,B,C,D TEMP </p> <p>Le code de température est indiqué ici.</p>
<p>The following warnings apply to products having C-UL and UL certification for use in hazardous locations.</p>	<p>Les avertissements suivants s'appliquent aux produits ayant la certification C-UL/UL pour une utilisation en environnements dangereux.</p>
<p>WARNING: Explosion Hazard</p> <ul style="list-style-type: none"> Substitution of components may impair suitability for Class I, Division 2. Do not replace components unless power has been switched off or the area is known to be non-hazardous. Do not disconnect equipment unless power has been switched off or the area is known to be non-hazardous. Do not disconnect connectors unless power has been switched off or the area is known to be non-hazardous. Secure any user-supplied connectors that mate to external circuits on this equipment by using screws, sliding latches, threaded connectors, or other means such that any connection can withstand a 15 Newton (3.4 lb.) separating force applied for a minimum of one minute. 	<p>AVERTISSEMENT : Risque d'explosion</p> <ul style="list-style-type: none"> La substitution de composants peut rendre ce matériel inadapté à une utilisation en environnements de Classe I, Division 2. Couper le courant ou s'assurer que l'environnement est classé non dangereux avant de remplacer des composants. Couper le courant ou s'assurer que l'environnement est classé non dangereux avant de débrancher l'équipement. Couper le courant ou s'assurer que l'environnement est classé non dangereux avant de débrancher les connecteurs. Fixer tous les connecteurs fournis par l'utilisateur pour se brancher aux circuits externes de cet équipement à l'aide de vis, loquets coulissants, connecteurs filetés ou autres, de sorte que les connexions résistent à une force de séparation de 15 Newtons (1,5 kg - 3,4 lb.) appliquée pendant au moins une minute. S'assurer que l'environnement est classé non dangereux avant de changer les piles.
<p>C-UL and UL logo is a registered trademark of the Underwriters Laboratories.</p>	<p>Les sigles C-UL et UL sont des marques déposées de la Underwriters Laboratories.</p>

Specifications

Specifications - RIO-DNP Communication Interface

Communication Interface Specifications

Expansion I/O Capacity	12 modules
Communication Rate	125K bit/s (500m maximum) 250K bit/s (250m maximum) 512K bit/s (100m maximum)
DeviceNet Power Requirements	24V dc (+4% = 25V dc max) @ 400mA maximum
Module Location	Starter module - left side of EH-RIO system

DeviceNet Power Specifications

Power Supply	Class 2 Supply - Note: In order to comply with CE Low Voltage Directives (LVD), you must use a Safety Extra Low Voltage (SELV) or a Protected Extra Low Voltage (PELV) power supply to power this interface.
Input Voltage Rating	24V dc nominal
Input Voltage Range	11-25V dc DeviceNet specification
Input Overvoltage Protection	Reverse polarity protected
Inrush Current	6A for 5ms
Indicators	2 green power supply status indicators: System Power (Backplane Bus 5V power) DeviceNet Power (24V from DeviceNet)

General Specifications

Output Current to Backplane Bus	1.3A maximum @ 5V dc $\pm 5\%$ (4.75-5.25)
Power Consumption	8.0W maximum @ 25V dc
Power Dissipation	1.2W maximum @ 25V
Thermal Dissipation	4.1 BTU/hr maximum @ 25V dc
Isolation Voltage	1528V rms @ 2593V dc
Field Power Bus Supply Voltage	10-28.8V dc range, 120V ac, or 240V ac
Supply Current	10A maximum
Dimensions Inches (Millimeters)	3.0H x 1.0W x 5.25L (76.2H x 25.4W x 133.4L)

10 EH-RIO DeviceNet Communication Interface

Environmental Conditions											
Operational Temperature	-20 to 55°C (-4 to 131°F)										
Storage Temperature	-40 to 85°C (-40 to 185°F)										
Relative Humidity	5 to 95% noncondensing										
Shock	30g peak acceleration, 11(±1)ms pulse width										
Operating											
Non-operating	50g peak acceleration, 11(±1)ms pulse width										
Vibration	Tested 5g @ 10-500Hz per IEC 68-2-6										
Conductors Wire Size	14 AWG (2.5mm ²) - 22 AWG (0.25mm ²) solid or stranded wire rated @ 75°C or higher 3/64 inch (1.2mm) insulation maximum										
Terminal Base Screw Torque	7 pound-inches (0.6Nm)										
Field Wiring Terminations DeviceNet	<table> <tr> <td>1 - Black Wire</td> <td>-V</td> </tr> <tr> <td>2 - Blue Wire</td> <td>CAN Low</td> </tr> <tr> <td>3 - Bare Wire</td> <td>Shield</td> </tr> <tr> <td>4 - White Wire</td> <td>CAN High</td> </tr> <tr> <td>5 - Red Wire</td> <td>+V</td> </tr> </table>	1 - Black Wire	-V	2 - Blue Wire	CAN Low	3 - Bare Wire	Shield	4 - White Wire	CAN High	5 - Red Wire	+V
1 - Black Wire	-V										
2 - Blue Wire	CAN Low										
3 - Bare Wire	Shield										
4 - White Wire	CAN High										
5 - Red Wire	+V										
Power Supply	<table> <tr> <td>0 - No Connection</td> <td>1 - No Connection</td> </tr> <tr> <td>2 - Chassis Ground</td> <td>3 - Chassis Ground</td> </tr> <tr> <td>4 - Common</td> <td>5 - Common</td> </tr> <tr> <td>6 - Supply</td> <td>7 - Supply</td> </tr> </table>	0 - No Connection	1 - No Connection	2 - Chassis Ground	3 - Chassis Ground	4 - Common	5 - Common	6 - Supply	7 - Supply		
0 - No Connection	1 - No Connection										
2 - Chassis Ground	3 - Chassis Ground										
4 - Common	5 - Common										
6 - Supply	7 - Supply										
Mass	4.56 oz/129.3grams										
Agency Certification (when product is marked)	C-UL Listed C-UL Class I, Division 2, Groups A, B, C and D certified UL Listed CE marked for all applicable directives. DeviceNet compatible as certified by ODVA, Inc.										

HITACHI