

Installation Instructions

EH-RIO 24V Encoder/Counter Module (RIO-CU24L)

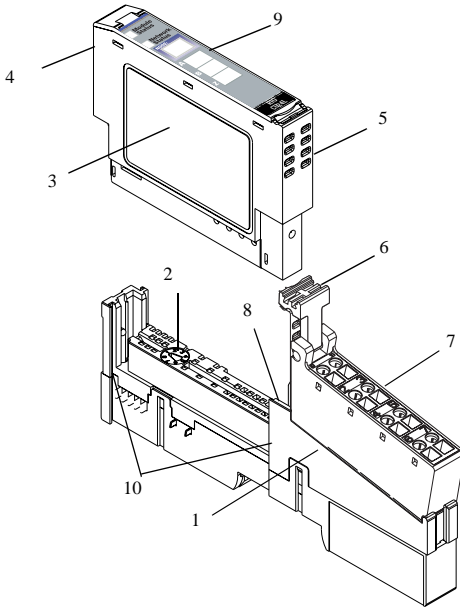

41825CU24L

	Description		Description
1	Mounting Base ¹	6	RTB Removal Handle
2	Mechanical Keying (orange)	7	Removable Terminal Block (RTB) ¹
3	Module Wiring Diagram	8	DIN Rail Locking Screw (orange)
4	Module Locking Mechanism	9	Slide-in Writable Label
5	Insertable I/O Module	10	Interlocking Side Pieces

¹Wiring Base Assembly consists of item 1) mounting base, RIO-MB and item 7) removable terminal block, RIO-BSC or -BSP.

ATTENTION



Installing the Mounting Base

To install the mounting base on the DIN rail, proceed as follows. Make sure the mounting base locking screw is horizontal referenced to the mounting base.

1. Position the mounting base vertically above the installed units (adapter, power supply or existing module).
2. Slide the mounting base down allowing the interlocking side pieces to engage the adjacent module or adapter.
3. Press firmly to seat the mounting base on the DIN rail. The mounting base will snap into place.
4. To remove the mounting base from the DIN rail, remove the module, and use a small bladed screwdriver to rotate the base locking screw to a vertical position. This releases the locking mechanism. Then lift straight up to remove.

Installing the I/O Module

The module can be installed before, or after base installation. Make sure that the mounting base is correctly keyed before installing the module into the mounting base. In addition, make sure the mounting base locking screw is positioned horizontal referenced to the base.

1. Using a bladed screwdriver, rotate the keyswitch (2) on the mounting base clockwise until the number required for the type of module being installed aligns with the notch in the base.
2. Make certain the DIN rail locking screw is in the horizontal position. (You cannot insert the module if the locking mechanism is unlocked.)

3. Insert the module straight down into the mounting base and press to secure. The module will lock into place.
-

WARNING

When you connect or disconnect the Removable Terminal Block (RTB) with field side power applied, an electrical arc can occur. This could cause an explosion in hazardous location installations.

Be sure that power is removed or the area is nonhazardous before proceeding.

Installing the Removable Terminal Block (RTB)

A removable terminal block is supplied with your wiring base assembly. To remove, pull up on the RTB handle. This allows the mounting base to be removed and replaced as necessary without removing any of the wiring. To reinsert the removable terminal block, proceed as follows.

1. Insert the end opposite the handle into the base unit. This end has a curved section that engages with the wiring base.
 2. Rotate the terminal block into the wiring base until it locks itself in place.
 3. If an I/O module is installed, snap the RTB handle into place on the module.
-

WARNING

When you connect or disconnect the Removable Terminal Block (RTB) with field side power applied, an electrical arc can occur. This could cause an explosion in hazardous location installations.

Be sure that power is removed or the area is nonhazardous before proceeding.

Removing a Mounting Base

To remove a mounting base, you must remove any installed module in the base, and the module installed in the base to the right. Remove the removable terminal block (if wired).

1. Unlatch the RTB handle on the I/O module.
2. Pull on the RTB handle to remove the removable terminal block.

WARNING



When you connect or disconnect the Removable Terminal Block (RTB) with field side power applied, an electrical arc can occur. This could cause an explosion in hazardous location installations.

Be sure that power is removed or the area is nonhazardous before proceeding.

-
3. Press on the module lock on the top of the module.
 4. Pull on the I/O module to remove from the base.

WARNING



When you insert or remove the module while backplane power is on, an electrical arc can occur. This could cause an explosion in hazardous location installations. Be sure that power is removed or the area is nonhazardous before proceeding.

-
5. Repeat steps 1, 2, 3 and 4 for the module to the right.
 6. Use a small bladed screwdriver to rotate the orange base locking screw to a vertical position. This releases the locking mechanism.
 7. Then lift straight up to remove.

European Communities (EC) Directive Compliance

If this product has the CE mark it is approved for installation within the European Union and EEA regions. It has been designed and tested to meet the following directives.

EMC Directive

This product is tested to meet the Council Directive 89/336/EC Electromagnetic Compatibility (EMC) by applying the following standards, in whole or in part, documented in a technical construction file:

- EN 50081-2 EMC — Generic Emission Standard, Part 2 — Industrial Environment
- EN 50082-2 EMC — Generic Immunity Standard, Part 2 — Industrial Environment

This product is intended for use in an industrial environment.

Low Voltage Directive

This product is tested to meet Council Directive 73/23/EEC Low Voltage, by applying the safety requirements of EN 61131-2 Programmable Controllers, Part 2 - Equipment Requirements and Tests. For specific information required by EN 61131-2, see the appropriate sections in this publication, as well as publication 1770-4.1, Allen-Bradley Industrial Automation Wiring and Grounding Guidelines.

Open style devices must be provided with environmental and safety protection by proper mounting in enclosures designed for specific application conditions. See NEMA Standards publication 250 and IEC publication 529, as applicable, for explanations of the degrees of protection provided by different types of enclosures.

Communicating with the RIO-CU24L Encoder/Counter

I/O messages are sent to (consumed) and received from (produced) the EH-RIO modules. These messages are mapped into the processor's memory. This EH-RIO input/output module produces 6 bytes of input data (scanner Rx) (status). It consumes 1 byte of I/O data (scanner Tx).

Default Data Map for the Encoder/Counter Module

Message size: 6 Bytes

	15	14	13	12	11	10	09	08	07	06	05	04	03	02	01	00
Produces (scanner Rx)	Channel 0 value of present counter state (LSW)															
	Channel 0 value of present counter state (MSW)															
	P	E	N	0	0	0	0	0	0	Z	B	A	C	C	Z	0
E	F	R							S	S	S	1	0	D		0
Where:PE = Programming error EF = EEPROM fault status NR = Not ready status bit ZS = Z input status BS = B input status AS = A input status C = Stored data count ZD = Zero frequency detected LSW = Least significant word MSW = Most significant word																

NOTE: When a configuration is sent to the module, it is checked for consistency before being applied. If an error is found in the configuration, the PE bit is asserted and the module retains its previous configuration. Monitor this PE bit with your user program to isolate any problems an improperly configured module may have. If the configuration is considered acceptable, the counter ASIC is disabled and counting is suspended while the ASIC is loaded with the new operational parameters.

Message size: 1 bytes

	07	06	05	04	03	02	01	00
Consumes (scanner Tx)	0	0	0	0	0	VR	CP	CR
Where:VR = Value reset of stored/accumulated count CP = Counter preset CR = Counter reset								

Configuring Your Encoder/Counter Module

Parameter	Set/Get	Description	Bytes
1	Set/Get	Counter Configuration	1
2	Set/Get	Filter Selection	1
3	Set/Get	Decimal Position	1
4	Set/Get	Reserved	1
5	Set/Get	Time Base Value	2
6	Set/Get	Gate Interval	1
7	Set/Get	Channel Scalar	1
8	Set/Get	Channel Rollover Value	4
9	Set/Get	Channel Preset Value	4
10	Set/Get	Counter Control Safe State	1

Counter Configuration

07	06	05	04	03	02	01	00	
ZI	MD			CF				Counter 0
				0	0	0	0	Counter
				0	0	0	1	Encoder X1
				0	0	1	0	Encoder X2
				0	0	1	1	Not used
				0	1	0	0	Encoder X4
				0	1	0	1	Period/Rate
				0	1	1	0	Not used
				0	1	1	1	Rate Measurement
	0	0	0					Store Count Disabled
	0	0	1					Mode 1 - store/continue
	0	1	0					Mode 2 - store/wait/resume
	0	1	1					Mode 3 - store, reset/wait/start
	1	0	0					Mode 4 - store, reset/start
	1	0	1					Reserved
	1	1	0					Reserved
	1	1	1					Reserved
0								Z input - 0 = not inverted
1								Z input - 1 = inverted

Filter Selection

07	06	05	04	03	02	01	00	
0	ZF	BF	AF	FS				
				0	0	0	0	No Filter
				0	0	0	1	50kHz (10 μ s + 0 μ s/-1.6 μ s)
				0	0	1	0	5kHz (100 μ s + 0 μ s/-13.2 μ s)
				0	1	0	0	500Hz (1.0ms + 0 μ s/-125 μ s)
				1	0	0	0	50Hz (10ms + 0ms/-1.25ms)
			0					A input not filtered
			1					A input filtered
		0						B input not filtered
		1						B input filtered
	0							Z input not filtered
	1							Z input filtered

Scalar Selection

07	06	05	04	03	02	01	00	Scalar ¹
0	0	0	0	0	0	0	1	Z - F _{min} = 0.149Hz
0	0	0	0	0	0	1	0	Z/2 - F _{min} = 0.298Hz
0	0	0	0	0	1	0	0	Z/4 - F _{min} = 0.596Hz
0	0	0	0	1	0	0	0	Z/8 - F _{min} = 1.192Hz
0	0	0	1	0	0	0	0	Z/16 - F _{min} = 2.384Hz
0	0	1	0	0	0	0	0	Z/32 - F _{min} = 4.768Hz
0	1	0	0	0	0	0	0	Z/64 - F _{min} = 9.537Hz
1	0	0	0	0	0	0	0	Z/128 - F _{min} = 19.073Hz

1 Where F_{min} indicates the frequency at which the zero frequency detect is asserted due to counter overflow.

Assemblies

The Encoder/Counter Module uses several words to communicate real time input and output data as well as non-real time module information (i.e. description, revision, etc) and configuration. The following table shows the words which must be exchanged.

Data can be read (get) or written (set) using an Explicit Message.

Instance	Services	Field	Bytes
#101 (0x65)	Get	Present Channel Data	4
		Status	2
#102 (0x66)	Get	Stored Channel Data	4
		Status	2
#103 (0x67)	Get	Present Channel Data	4
		Stored Channel Data	4
		Status	2
#104 (0x68)	Get	Programming Error Code	2
#105 (0x69)	Set/Get	Counter Control	1
#106 (0x6a)	Set/Get	Counter Configuration	1
		Filter Selection	1
		Decimal Position	1
		Reserved	1
		Time Base	2
		Gate Interval	1
		Scalar	1
		Rollover Value	4
		Preset Value	4
		Counter Control SSV	1

Wiring the Encoder/Counter Module

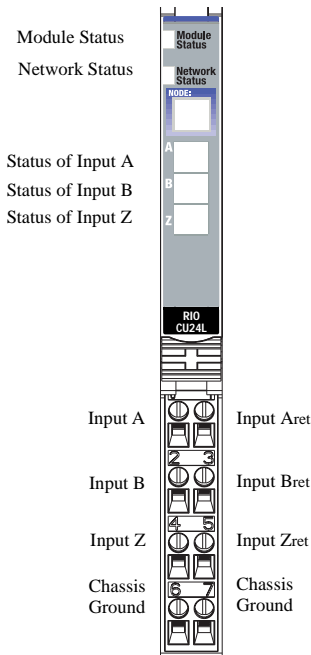

42016

0 A	1 Aret
2 B	3 Bret
4 Z	5 Zret
6 Chas Gnd	7 Chas Gnd

A, B and Z , and Aret, Bret,
and Zret are inputs
Chas Gnd = Chassis ground

Termination	Definition	Termination	Definition
0	A	4	Z
1	Aret	5	Zret
2	B	6	Chassis ground
3	Bret	7	Chassis ground

Troubleshooting with the Indicators

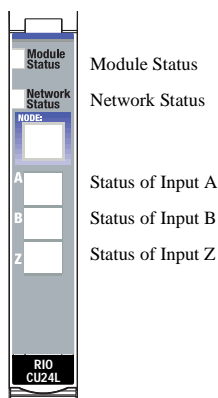



42016CU24L

Indication	Probable Cause
Module Status	
Off	No power applied to device
Green	Device operating normally
Flashing Green	Device needs commissioning due to configuration missing, incomplete or incorrect.
Flashing Red	Recoverable fault.
Red	Unrecoverable fault may require device replacement
Flashing Red/Green	Device is in self-test

Indication	Probable Cause
Network Status	
Off	Device is not on-line - Device has not completed dup_MAC_id test. - Device not powered - check module status indicator
Flashing Green	Device is on-line but has no connections in the established state.
Green	Device on-line and has connections in the established state.
Flashing Red	One or more I/O connections in timed-out state
Red	Critical link failure - failed communication device. Device detected error that prevents it communicating on the network.
Flashing Red/Green	Communication faulted device - the device has detected a network access error and is in communication faulted state. Device has received and accepted an Identify Communication Faulted Request - long protocol message.

Indication	Probable Cause
Input Status	
Off	Input inactive
Yellow	Input is active and under control

Safety Approvals

<p>The following information applies when operating this equipment in hazardous locations:</p>		<p>Informations sur l'utilisation de cet équipement en environnements dangereux:</p>	
<p>Products marked "CL I, DIV 2, GP A, B, C, D" are suitable for use in Class I Division 2 Groups A, B, C, D, Hazardous Locations and nonhazardous locations only. Each product is supplied with markings on the rating nameplate indicating the hazardous location temperature code. When combining products within a system, the most adverse temperature code (lowest "T" number) may be used to help determine the overall temperature code of the system. Combinations of equipment in your system are subject to investigation by the local Authority Having Jurisdiction at the time of installation.</p>		<p>Les produits marqués "CL I, DIV 2, GP A, B, C, D" ne conviennent qu'à une utilisation en environnements de Classe I Division 2 Groupes A, B, C, D dangereux et non dangereux. Chaque produit est livré avec des marquages sur sa plaque d'identification qui indiquent le code de température pour les environnements dangereux. Lorsque plusieurs produits sont combinés dans un système, le code de température le plus défavorable (code de température le plus faible) peut être utilisé pour déterminer le code de température global du système. Les combinaisons d'équipements dans le système sont sujettes à inspection par les autorités locales qualifiées au moment de l'installation.</p>	
<p>WARNING</p> 	<p>EXPLOSION HAZARD -</p> <ul style="list-style-type: none"> Do not disconnect equipment unless power has been removed or the area is known to be nonhazardous. Do not disconnect connections to this equipment unless power has been removed or the area is known to be nonhazardous. Secure any external connections that mate to this equipment by using screws, sliding latches, threaded connectors, or other means provided with this product. Substitution of components may impair suitability for Class I, Division 2. If this product contains batteries, they must only be changed in an area known to be nonhazardous. 	<p>AVERTISSEMENT</p> 	<p>RISQUE D'EXPLOSION –</p> <ul style="list-style-type: none"> Couper le courant ou s'assurer que l'environnement est classé non dangereux avant de débrancher l'équipement. Couper le courant ou s'assurer que l'environnement est classé non dangereux avant de débrancher les connecteurs. Fixer tous les connecteurs externes reliés à cet équipement à l'aide de vis, loquets coulissants, connecteurs filetés ou autres moyens fournis avec ce produit. La substitution de composants peut rendre cet équipement inadapté à une utilisation en environnement de Classe 1, Division 2. S'assurer que l'environnement est classé non dangereux avant de changer les piles.

Specifications

Specifications - RIO-CU24L Encoder/Counter Module

Input Specifications

Number of Inputs	1 - 1 group of A/Areturn, B/Breturn and Z/Zreturn
Input Voltage	15-24V dc
Input Current	6.1mA @ 15V dc 10.2mA @ 24V dc
Input OFF-State Current	≤0.250mA max
Input OFF-State Voltage	≤1.8V dc
Input ON-State Current	≥5mA
Input ON-State Voltage	≥12.5V dc

Mass	1.15 oz/32.60 grams
Agency Certification (when product is marked)	c-UL-us - UL Listed Industrial Control Equipment, certified for US and Canada c-UL-us - UL Listed for Class I, Division 2, Groups A, B, C and D Hazardous locations, certified for US and Canada ODVA - ODVA Conformance tested to ODVA DeviceNet specifications

Input Derating Curve

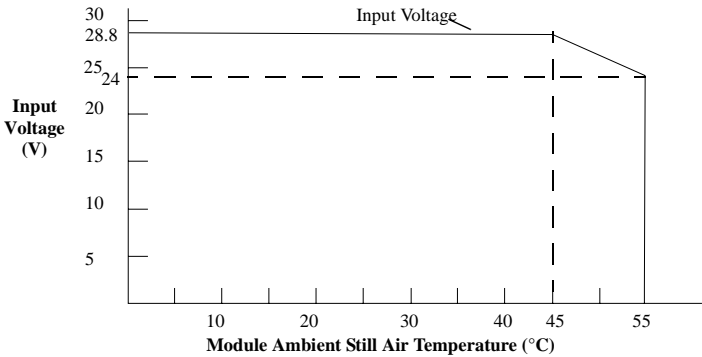

Note: Exceeding the maximum input voltage can cause permanent damage to the input.

HITACHI